

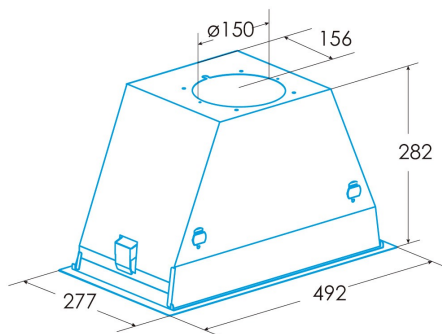

ECG-5811 X

Cod. 932271899

EAN 8435436110962



GENERAL INFORMATION

| | |
|-----------|---------------|
| EAN/UPC | 8435436110962 |
| Subfamily | Insert |

Product sheet according to directives EU65/2014 - EN61591, EN60704-2-13, EN50564

| | |
|---|-------|
| AEC (Annual energy consumption) (kWh/year) | 106,3 |
| EEL class (energy efficiency class) | C |
| FDE (fluid dynamic efficiency) | 15,7 |
| FDE class (fluid dynamic efficiency class) | D |
| LE (light efficiency) (lux/W) | 24,3 |
| LE class (light efficiency class) | B |
| GFE (grease filtering efficiency) | 91,2 |
| GFE class (grease filtering efficiency class) | B |
| Airflow in normal mode MIN (m3/h) | 300 |
| Airflow in normal mode MAX (m3/h) | 645 |
| Acoustic power in normal mode MIN (dB) | 50 |
| Acoustic power in normal mode MAX (dB) | 65 |
| Po (energy consumption in off mode) (W) | 0 |
| Ps (energy consumption in standby mode) (W) | 0 |

Integration directive EU 66/2014

| | |
|--|-------|
| f (time increase factor) | 1,4 |
| EEL (Energy Efficiency Index) | 84,7 |
| QBEP (maximum efficiency at air flow point) (m3/h) | 419,7 |
| PBEP (maximum efficiency at pressure point) (Pa) | 261 |
| WBEP (power consumption at maximum efficiency) (W) | 193,5 |
| WL (nominal power lighting system) (W) | 7 |
| EMIDDLE (Average illuminance on the cooking surface) (lux) | 170 |

External Dimensions

| | |
|---------------------------|----------|
| Width (mm) | 492 |
| Depth (mm) | 277 |
| Maximum total height (mm) | 280 |
| Minimum total height (mm) | 280 |
| Diamètre de sortie (mm) | 150, 125 |

Characteristics

| | |
|---------------------------------------|------------------------|
| Motor quantity | 1 |
| Motor model | BT2 |
| Maximum pressure (Pa) | 405 |
| Filter technology | Aluminium mesh |
| Control technology | Mechanical push button |
| Booster | - |
| Power levels | 3 |
| Timer | - |
| Filter saturation indicator | - |
| Charcoal filter replacement indicator | - |
| Dimmer function | - |
| Connectivity | - |
| Remote control | - |
| Display | - |

Lighting

| | |
|----------------|--------|
| Light model | ECOLED |
| Ray technology | LED |

Installation

| | |
|---|----------|
| Minimum distance to electric plate (mm) | 550 |
| Minimum distance to gas plate (mm) | 650 |
| Recirculation option | √ |
| Charcoal filter | - |
| Back draught shutter | Included |
| Inner shield | - |

Electric connection

| | |
|------------------------|---------|
| Nominal voltage (V) | 220-240 |
| Nominal frequency (Hz) | 50/60 |

| | |
|---------------------------|----------|
| Nominal input power (W) | 207 |
| Electric shock protection | Class II |
| Power cord length (m) | 1,5 |

Accessories

| | |
|---------------------------------|----------|
| Upper decorative duct extension | No |
| White decorative duct | No |
| Black decorative duct | No |
| Island tube booster | No |
| Back draught shutter | Included |
| MAX PRO Metal filter | No |
| Activated charcoal filter | 2859398 |
| Noiseless flexible duct | 2893002 |
| Recirculation kit | No |
